

Assembly Instructions: Zero-Clearance Insert Bosch GTS 10 XC - KIT

Congratulations for purchasing the Zero-Clearance Insert Kit for the Bosch GTS10 XC (US Modell 4100).

Preparation

Before mounting the insert, you have to prepare the insert for mounting. Note: Tasks which are not mandatory are marked as „optional“.

1	Using a cutter or sharp knife all CNC-remainings at the outer side and in the hole for the riving knife are removed. The preciser you work here, the less sanding work remains.
2	Optional: Sanding of the outer side
3	Optional: Bevel the edge on the top. Note: The edge at the rear side cannot be sanded easily due to the two small brackets. Since the wood in the tablesaw is moved from front to back this is not critical.
4	NOT optional: Use a countersink to bevel the 4 holes for the screws from below. If you skip this step you risk to crack the lower side when inserting the screws.
5	Optional: Use a countersink to bevel the 4 holes on the surface.
6	Now apply gently the 4 set screws. Take care to mount them perpendiculary.
7	Finally fix the ball lock at the center of the front from below. A distance of 1-2mm between the edge of the lock and the insert proved well. If this distance is too small, it will result in a high tension between lock and saw that can damage the insert while removal.

Contact: Kai Altstaedt, info@ck-altstaedt.de
Homepage: <http://www.lambdasign.de/>
Instagram: <http://www.instagram.com/lambdasign>



Preparation (Sketch)

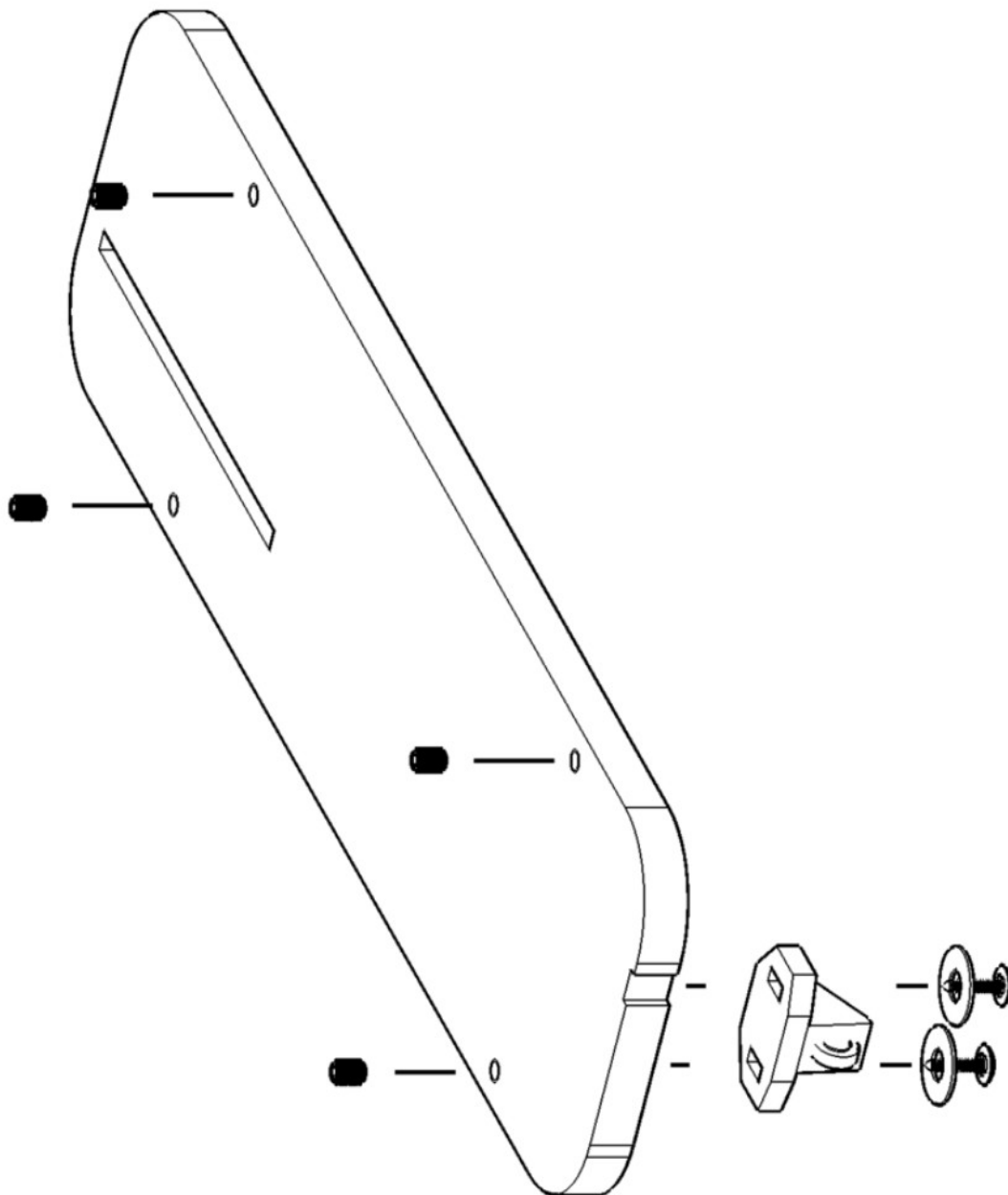

Mounting

After the preparation only few steps are missing before you can use your insert. All steps are also shown in the product video accessible through www.lambdasign.de.

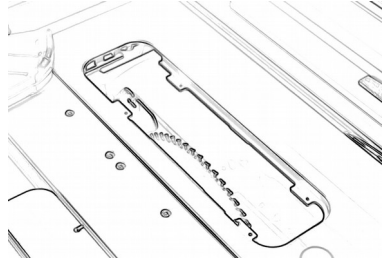
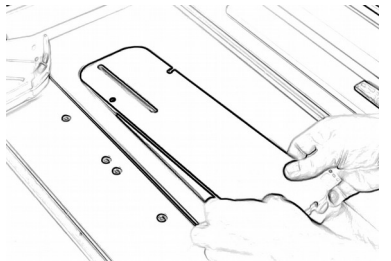
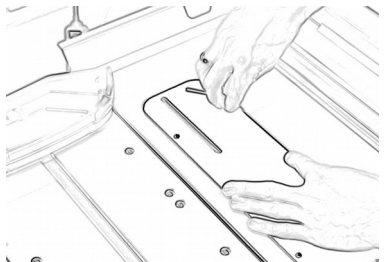
1	<p>Remove the protection cap and lower the saw blade completely. Please remove now the original insert.</p>	
2	<p>Mount then the Zero-Clearance insert into the saw table. The insert has a very tight fit by intention. You may adjust the form with a file. Please verify that the notch for the riving knife is over the riving knife.</p>	
3	<p>Using the hex wrench with the screws, you can adjust height of the insert. Please make sure, that the insert is in one plane with the saw table.</p>	
4	<p>Turn on the saw and lift the blade slowly to the highest position. While lifting press down the insert with the bar. Turn off the saw and mount the protection cap. Your insert is now ready to be used.</p>	